

# The neuroscience of tinnitus

Jos J. Eggermont<sup>1</sup> and Larry E. Roberts<sup>2</sup>

<sup>1</sup>Department of Physiology and Biophysics, and Department of Psychology, University of Calgary, Alberta, Canada, T2N 1N4

<sup>2</sup>Department of Psychology, McMaster University, Hamilton, Ontario, Canada, L8S 4K1

**Tinnitus is an auditory phantom sensation (ringing of the ears) experienced when no external sound is present. Most but not all cases are associated with hearing loss induced by noise exposure or aging. Neuroscience research has begun to reveal how tinnitus is generated by the brain when hearing loss occurs, and to suggest new avenues for management and prevention of tinnitus following hearing injuries. Downregulation of intracortical inhibition induced by damage to the cochlea or to auditory projection pathways highlights neural processes that underlie the sensation of phantom sound.**

Many, if not most, people have experienced ringing in their ears when no external sound is present. Typically the sensation is associated with a reversible cause – such as listening to loud music, fever, use of aspirin or quinine, or transient perturbations of the middle ear – and subsides over a period of time ranging from a few seconds to a few days. However, in 5–15% of the general population, the tinnitus sensation is unremitting [1]. Chronic tinnitus is more prevalent among seniors (12% after age 60) than in young adults (5% in the 20–30 age group) but can occur at any age. In 1–3% of the general population, the tinnitus sensation is sufficiently loud to affect the quality of life, involving sleep disturbance, work impairment and psychiatric distress [2]. Most cases of chronic tinnitus are associated with hearing loss that is induced by noise exposure or accompanies the aging process. The prevalence of tinnitus could be increasing as the senior population grows and as young people are increasingly exposed to industrial and recreational noise [3].

Tinnitus is of interest to auditory neuroscientists because it represents a meeting ground for neuroscience and problems of human health. It is a significant medical, psychological and workplace challenge for millions of people. Although a variety of procedures can help tinnitus sufferers adapt to and modulate their tinnitus sensation, at present there are no treatments that reliably eliminate tinnitus itself. Neuroscientists are, however, beginning to understand how tinnitus is generated when hearing loss occurs. Their findings suggest new approaches to the management and prevention of tinnitus and provide insight into the question of how the brain generates the sensation of sound.

## Is tinnitus in the ear or the brain?

Tinnitus sensations associated with hearing loss are usually localized towards the affected ear(s). Does this

mean that tinnitus is generated in the ear? This contentious issue, which has great implications for which types of treatment should be developed, can only be resolved in animal models that are conditioned to signal the presence of tinnitus following application of ototoxic drugs [4,5] or excessive noise [6]. There is limited support for the assumption that tinnitus is the result of increased spontaneous activity in auditory nerve fibers: evidence is found after high-dose application of salicylate [7], but low doses do not increase spontaneous firing rates (SFR) [8,9], even though tinnitus can be demonstrated behaviorally for low doses [5]. Other ototoxic drugs that cause tinnitus, such as quinine [10] and aminoglycosides [11], show a consistent decrease in the SFR of auditory nerve fibers. A similar decrease is reported after noise-induced hearing loss [12]. These results showing reduced SFR in auditory nerve fibers following noise exposure or ototoxicity point to a central cause of tinnitus, possibly related to changes in the balance of excitatory and inhibitory inputs conveyed to central auditory structures. Two qualifications here are that tinnitus can be prevented if NMDA receptor blockers are infused into the cochlea before salicylate application [13], and that prior administration of NMDA receptor blockers can limit hearing loss resulting from noise trauma [14]. It seems that by reducing the extent of the hearing loss, probably by preventing the neurotoxic effects of excessive glutamate release at cochlear NMDA receptors, the tinnitus is also prevented. These findings are consistent with the view that the origin of tinnitus lies in an imbalance of firing patterns across the tonotopic array of auditory nerve fibers [11], but not with the view that tinnitus reflects increased spontaneous activity generated there. Tinnitus sensations often persist even when input from the ear is removed by section of the auditory nerve [15].

Currently, most evidence based on SFR measurements points to changes in the central auditory system following dysfunction of the cochlear receptors as the source of tinnitus (Figure 1). Diminished output from the affected region causes reduced inhibition in central auditory structures [16–18], leading to hyperexcitability of the central auditory system [19,20]. This reduced inhibition has been indirectly demonstrated, after low-dose salicylate application, by the increase in SFR of neurons in the central (ICc) and external (ICx) nuclei of the inferior colliculus (IC) [21,22] and in secondary auditory cortex (AII) [23]. In primary auditory cortex (AI), a low dose of salicylate did not produce changes in SFR [24], whereas a high dose did [25]. After *cis*-platin application, SFR was increased in the dorsal cochlear nucleus (DCN) of hamsters [26]. Quinine application increased SFR in AII [23] but not

Corresponding author: Jos J. Eggermont (eggermont@ucalgary.ca).

Available online 9 September 2004

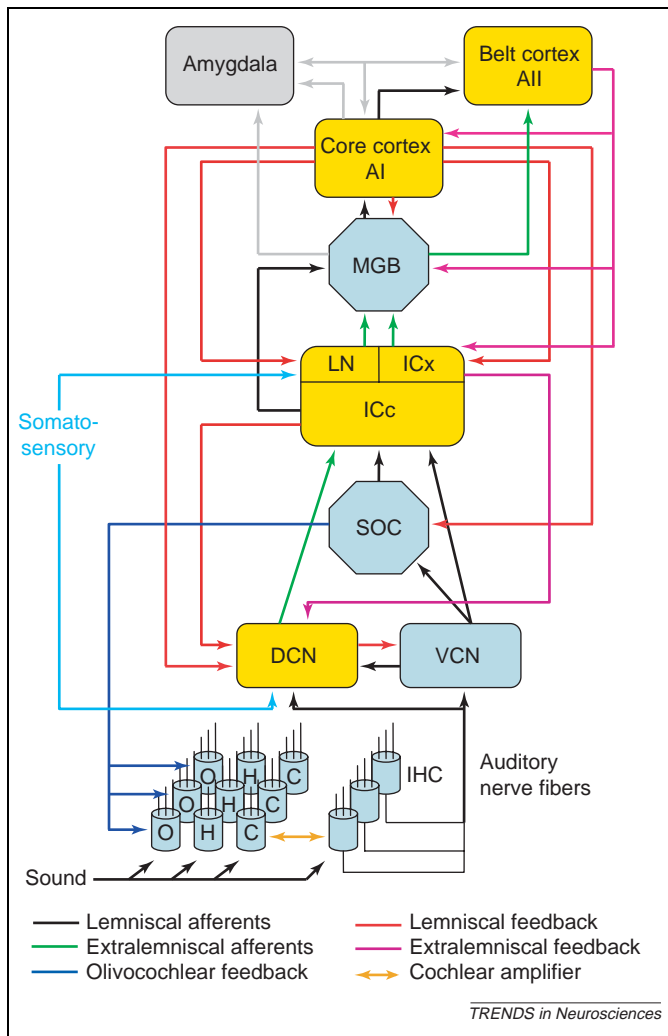

**Figure 1.** Schematic outline of the auditory system. This figure excludes binaural pathways and interhemispheric connections, but indicates parts where tinnitus-related studies have been conducted (yellow). Sound activates the outer hair cells (OHC) and inner hair cells (IHC) in the cochlea (bottom). The cochlea decomposes multi-frequency signals into a spatial output organized according to frequency; this is tonotopic mapping. The OHC act mainly as amplifiers of the mechanical movement of the basilar membrane, thereby sharpening the frequency resolution and enhancing sensitivity. Their working point and effectiveness are under control of the central auditory system (CAS), through olivocochlear bundle feedback (dark blue lines) from the superior olivary complex (SOC). The IHC are the mechano-electric transducers (microphones) in the cochlea, whose neural output forms the auditory nerve. Auditory nerve fibers bifurcate to send collaterals into both the ventral cochlear nucleus (VCN) and dorsal cochlear nucleus (DCN); both structures show tonotopic maps. Such mappings are found throughout the CAS and the nerve fiber tracts that propagate this frequency-specific information by the lemniscal pathway (thick black lines). The DCN, in addition to auditory nerve input, is also innervated by fibers from various parts of the somatosensory system (cyan), so this structure is a multi-modal processing station that is probably heavily involved in tinnitus resulting from, for example, orofacial movements and gaze changes. For that reason, this structure is considered here to be part of the extralemnisal pathway (green). Other parts of the extralemnisal pathway are the lateral nucleus (LN) and external nucleus (ICx) of the inferior colliculus, parts of the medial geniculate body (MGB) in the thalamus, and the secondary auditory cortex (All), which are all characterized by sensitivity to somatosensory stimuli. The MGB and auditory cortical areas project to the amygdala (top left), which is associated with fear conditioning and emotional processing. The CAS is characterized by strong reciprocal connections between various structures, and the descending parts consist of interconnected feedback loops that allow the cortex to modulate activity of the entire subcortical CAS. There are strong direct feedback connections between primary auditory cortex (AI) and DCN, as well as from auditory cortical areas via the central nucleus of the inferior colliculus (ICc). Thus, changes in cortical activity as a result of a loss of inhibition could change the subcortical activity in the ICc and DCN (directly) and even in the cochlea (indirectly via the olivocochlear bundle). Changes in the DCN, in turn, will directly affect the processing of lemniscal activity at the level of the VCN and the ICc. Thus, there could be a synergy between changes occurring in the cortex and those in the brainstem.

in AI [27]. Noise trauma increased SFR in DCN [28] and AI [29–31]. Studies in DCN after noise trauma found increased spontaneous activity in fusiform cells [32] and potentially also in cartwheel cells [33]. These findings (Table 1) point to an increase in SFR in cortical and subcortical auditory structures following noise trauma and exposure to ototoxic drugs. Whether increases in SFR relate directly to the sensation of tinnitus is, however, unclear. An interesting aspect is that, although tinnitus is often experienced immediately after noise exposure, increases in SFR took a few hours to materialize in AI [31] and several days to appear in DCN [34]. The temporal correlation of changes in SFR with the time course of tinnitus needs to be further investigated.

Two other possible correlates of tinnitus that have been investigated using animal models of hearing loss are burst firing and neural synchrony. Although burst firing increases after salicylate application in ICx [22], in cortical neurons the amount of bursting observed after salicylate or quinine application [24,27] or after noise trauma [29,30] does not change; transitory increases in AI after noise trauma return to baseline within a few hours [31]. A second feature of spontaneous activity in AI, the synchronization of the firings of several neurons as measured by cross-correlation, is increased immediately after a noise trauma for neurons in the affected frequency region [31], and also after quinine application [27]. Synchrony in the affected frequency region also increases with time and relates to reorganization of the cortical tonotopic representation by noise trauma (as will be described later). Thus, evidence for a strong central component in most cases of tinnitus is mounting. Evidence from human brain imaging studies confirms involvement of central structures in tinnitus and points to changes accompanying tinnitus not only in the inferior colliculus [35] and auditory cortex [36,37] but also in limbic structures associated with emotion [37]. These structures are modulated by activation of auditory nuclei that are also innervated by non-auditory inputs (e.g. the trigeminal nerve [38]), and can become activated as a consequence of removal of acoustic tumors or head and neck injury [39,40]. Multimodal inputs could be at work in cases where tinnitus is modulated by gaze or jaw-clenching or where hearing loss is absent [41]. Animal studies also suggest that metabolism after salicylate administration decreases in IC but increases in the auditory thalamus (medial geniculate body) and auditory cortex, as well as in the amygdala [42,43].

### Cortical reorganization in tinnitus

The animal research reviewed here investigated the response properties of neurons following hearing injuries or application of ototoxic drugs, and points to changes in the balance of excitation and inhibition at multiple levels of the projection pathway [5]. It is reasonable to assume that expression of these effects in the cortex contributes in some way to the perception of tinnitus. One change that has been well documented is alteration of tonotopic maps in AI following cochlear damage induced by noise trauma. In the intact cortex (Figure 2ai), there is an orderly tonotopic representation of spectral frequency across the auditory cortex in a caudal-to-rostral direction, which

**Table 1. Effects of drugs and trauma on spontaneous auditory activity and tinnitus<sup>a,b</sup>**

	Salicylate low dose	Salicylate high dose	Quinine		Cis-platin	Noise trauma		Refs
<b>Spontaneous activity</b>	<b>Rate</b>	<b>Rate</b>	<b>Rate</b>	<b>Synch.</b>	<b>Rate</b>	<b>Rate</b>	<b>Synch.</b>	
Auditory nerve fibers	≈	↑	↓	NS	↓	↓	NS	[7–13]
Dorsal cochlear nucleus	NS	NS	NS	NS	↑	↑	NS	[26,28,32–34]
Inferior colliculus	↑	NS	NS	NS	NS	NS	NS	[21,22]
Primary auditory cortex	≈	↑	≈	↑	NS	↑	↑	[24,25,27,29–31,44]
Secondary auditory cortex	↑	NS	↑	NS	NS	NS	NS	[23]
<b>Tinnitus</b>								
Behavioral tinnitus	Yes	Yes	Yes	Yes	Yes	Yes	Yes	[5,53,55]

<sup>a</sup>Rate and synchrony (synch.) of spontaneous activity in parts of the auditory system can be affected by drugs and noise trauma. ↑ indicates a significant increase, ↓ indicates significant decrease and ≈ indicates no change. 'Yes' indicates that tinnitus has been signaled behaviorally after administration of the drug or trauma.

<sup>b</sup>Abbreviation: NS, not studied.

reflects place coding of sound frequency by the basilar membrane of the cochlea. After noise trauma, tonotopic organization in the cortex is changed such that cortical neurons with characteristic frequencies (CFs) in the

frequency region of the hearing loss no longer respond according to their place in the tonotopic map but reflect instead the frequency tuning of their less affected neighbors (Figure 2a,ii) [29,44]. Neurons with CFs in the

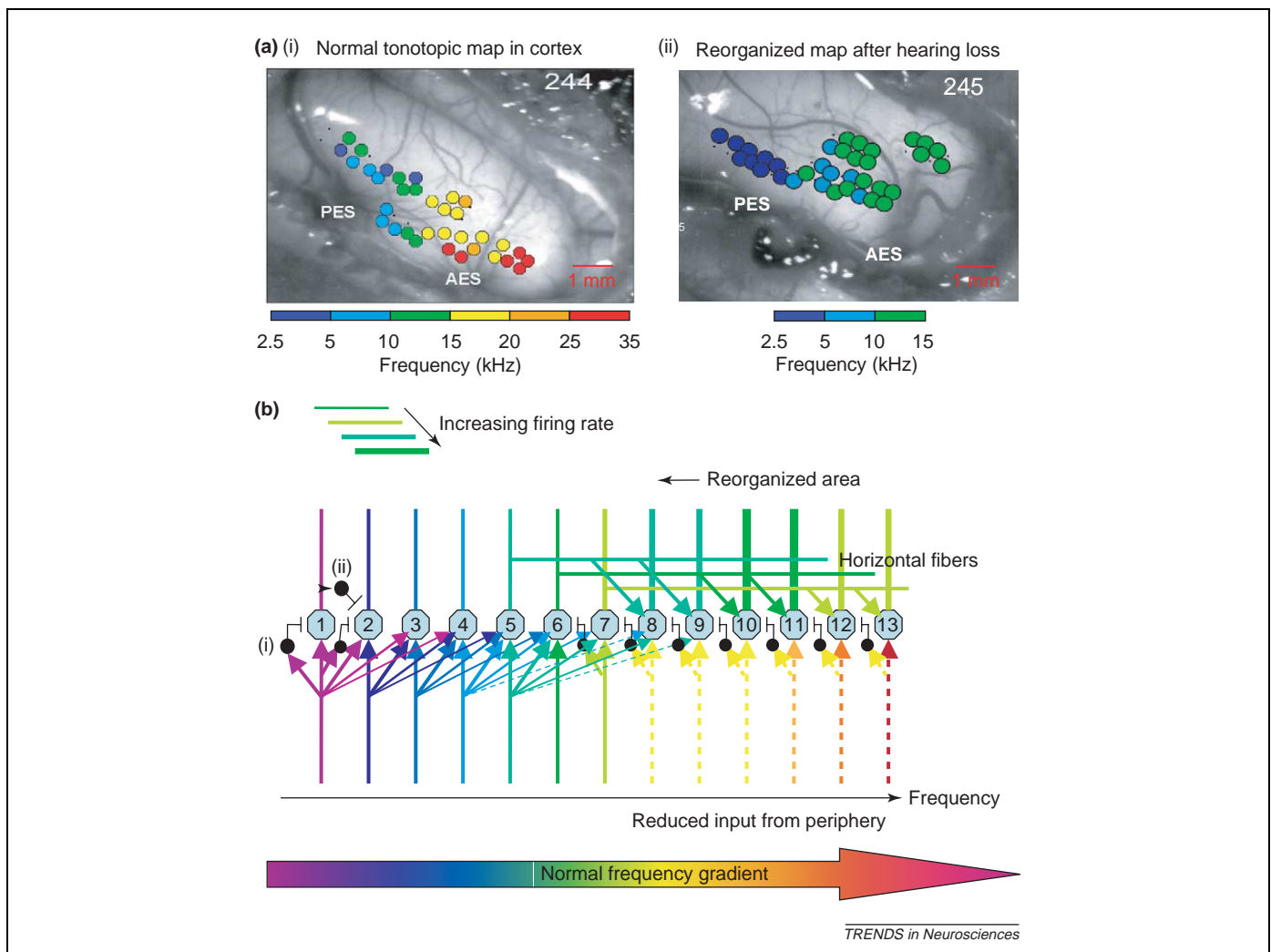

**Figure 2.** Normal and reorganized tonotopic maps in primary auditory cortex (AI). (a) The characteristic frequency at each recording site is color-coded and overlaid on a photograph of the cortical surface for a control cat (i) and a cat with a noise induced hearing loss (ii). The hearing loss was limited to frequencies > 10 kHz and amounted to 3 dB at 12 kHz, 12 dB at 16 kHz, 22 dB at 24 kHz and 23 dB at 32 kHz. (244 and 245 are cat identification numbers.) (b) The effect of restricted high-frequency hearing loss on the input to pyramidal cells (numbered 1–13) in auditory cortex. The large colored arrow shows the normal frequency gradient of the inputs conveying the tonotopic mapping. The thin vertical lines leading to the cortical cells are color-coded to reflect their frequency-specific input from the thalamus. For the higher frequencies, covering the range of the hearing loss, the lines are shown as dashed to indicate their reduced ability to activate cortical cells at low stimulus levels and during silence. Numerous divergent connections lead from each thalamic cell to a range of cortical cells (indicated by lines with the same color). A few inhibitory feedforward connections are indicated [one is labeled (i) on the left]. These affect the same cells that receive their thalamic inputs. Feedback inhibition is also prevalent but is only shown for cell 1 (ii). The assumption is that loss of input limits not only the excitation but also, even more strongly, the inhibitory feedforward activity. As a result, the diverging thalamic inputs from neighboring unaffected cells, and the inputs from cortical cells via horizontal fibers, face less competition from inhibition at those cortical cells deprived from thalamic input. Thus, these excitatory inputs are disinhibited or 'unmasked' and can impose their own frequency-selective inputs on cortical cells in the hearing loss range, which will ultimately result in a reorganization of the tonotopic map in the hearing-loss animal. Abbreviations: AES, anterior ectosylvian sulcus; PES, posterior ectosylvian sulcus.

affected region also show increased spontaneous activity and increased neural synchrony [30,31]. Magnetoencephalography studies in human tinnitus subjects [45] concur that the frequency region corresponding to the tinnitus pitch is represented abnormally in auditory cortex. This appears to be correlated with the perceived strength of the tinnitus but not with the amount of hearing loss, which is the primary determinant of changes in tonotopic maps [46]. The finding of altered tonotopic organization in tinnitus and in animal models of hearing loss suggests an analogy with a study finding that phantom limb pain correlated with reorganized somatotopic maps in human amputees [47]. These results point to potential links between reorganization of the cortical tonotopic map, changes in neuron response properties, and tinnitus.

### Listening to tinnitus

Changes in cortical organization and in neural dynamics that occur after exposure to noise or tinnitus-inducing drugs should relate to what the tinnitus subject hears. But which changes correlate with the perception of tinnitus?

One possibility is that over-representation in the cortical tonotopic map of edge frequencies (i.e. those frequencies at the low-frequency and/or high-frequency borders of the hearing loss that have near normal thresholds) is itself responsible for the tinnitus sensation [48]. This hypothesis proposes that neurons in a de-afferented cortical region shift their tuning to represent frequencies near the edge of the lesion, thus giving rise to an expanded representation of these frequencies and to the sensation of tinnitus (Figure 2b). The expanded representation appears to have perceptual consequences, because tinnitus subjects with hearing loss exhibit reduced thresholds [49] and enhanced frequency discrimination [50] for sound frequencies at the edge of the de-afferented zone, in addition to an augmented N1 component of the auditory evoked potentials in response to these frequencies [51]. However, this hypothesis also implies that tinnitus subjects should localize tinnitus frequencies near the edge frequency of hearing loss in the audiogram (typically 2–4 kHz in tinnitus associated with noise-induced hearing loss). Psychoacoustic findings do not support this hypothesis. Tinnitus subjects give variable frequency matches between and within sessions when asked to match pure tones to the frequency of their tinnitus [52,53]. This would be expected if tinnitus were to comprise a range of frequencies even when described as tonal rather than hissing. This interpretation is supported by results obtained when tinnitus subjects are asked to rate pure tones covering a wide range of frequencies for similarity to their tinnitus sensation: frequencies at audiometric edges are not rated as more similar to tinnitus than are other frequencies in the region of hearing loss, and frequencies in the range of normal hearing are not associated with tinnitus [54]. Instead, subjects identify a range of frequencies spanning the region of their hearing loss as resembling their tinnitus sensation (Figure 3). These results imply that, even though expansion of the cortical representation for edge frequencies appears to be functional, the expanded

representation is not itself the neural substrate of tinnitus. The activity of the affected neurons is heard in accordance with their original thalamocortical tuning and location in the cortical place map, and gives rise to the sensation of tinnitus.

If expansion of edge frequency representations is not the source of the tinnitus sensation, other properties of neural activity in the tonotopic region of hearing loss must underlie tinnitus. Two candidates identified by the animal studies already reviewed are increases in SFR in cortical and subcortical structures and increases in neural synchrony in the cortex following de-afferentation. Although hearing losses of <25 dB do not produce cortical map changes (suggesting that input arising from thalamic afferents dominates input via lateral fibers at this level of hearing impairment), hearing losses of this magnitude do result in diminished cortical inhibition [46] and accompanying increases in SFR. However, changed SFRs do not appear to track tinnitus as closely as do changes in neural synchrony. Although increases in SFR have been reported both within and outside of the reorganized region after hearing loss, the changes in neural synchrony that have been documented to date appear to be confined to the reorganized region of the cortex. Ratings of the tinnitus percept by sufferers appear to be similarly constrained to this region, implicating neural synchrony as the more likely source of the tinnitus percept.

Other psychoacoustic properties of tinnitus suggest that neural dynamics in the affected region contribute to the tinnitus sensation. It is well known that external sounds can 'mask' tinnitus. In ~50% of tinnitus sufferers the most effective sounds resemble the spectral properties of the tinnitus [55], suggesting that suprathreshold input to the region of hearing loss could be segregating neural activity in this region. The same process might explain why loudness estimates of tinnitus obtained by adjusting the intensity of a comparison tone are typically lower when the comparison frequencies are inside (2–3 dB) rather than outside (10–15 dB) the tinnitus region [56]. If suprathreshold masking sounds are presented continuously for ~30–60 s and then switched off, the tinnitus sensation disappears and then gradually recovers over a time period ranging from seconds to minutes. This phenomenon of 'residual inhibition' has been reported to be more robust when masking sounds encroach into the tinnitus frequency region, although not all subjects show this frequency dependence [56]. Another prominent feature of tinnitus is its increased prevalence in the elderly population, where high-frequency hearing loss is common. Although changes in the balance of excitation and inhibition associated with aging could contribute to age-related changes in tinnitus [57], hearing impairment might also contribute as the segregating effect of high-frequency input to the cortical place map is lost, allowing tinnitus to occur. Many tinnitus sufferers report that tinnitus diminishes when their high-frequency hearing losses are compensated by a hearing aid [58].

### Plasticity gone wrong?

It is unlikely that changes in neural activity (response properties of neurons and cortical organization) that are

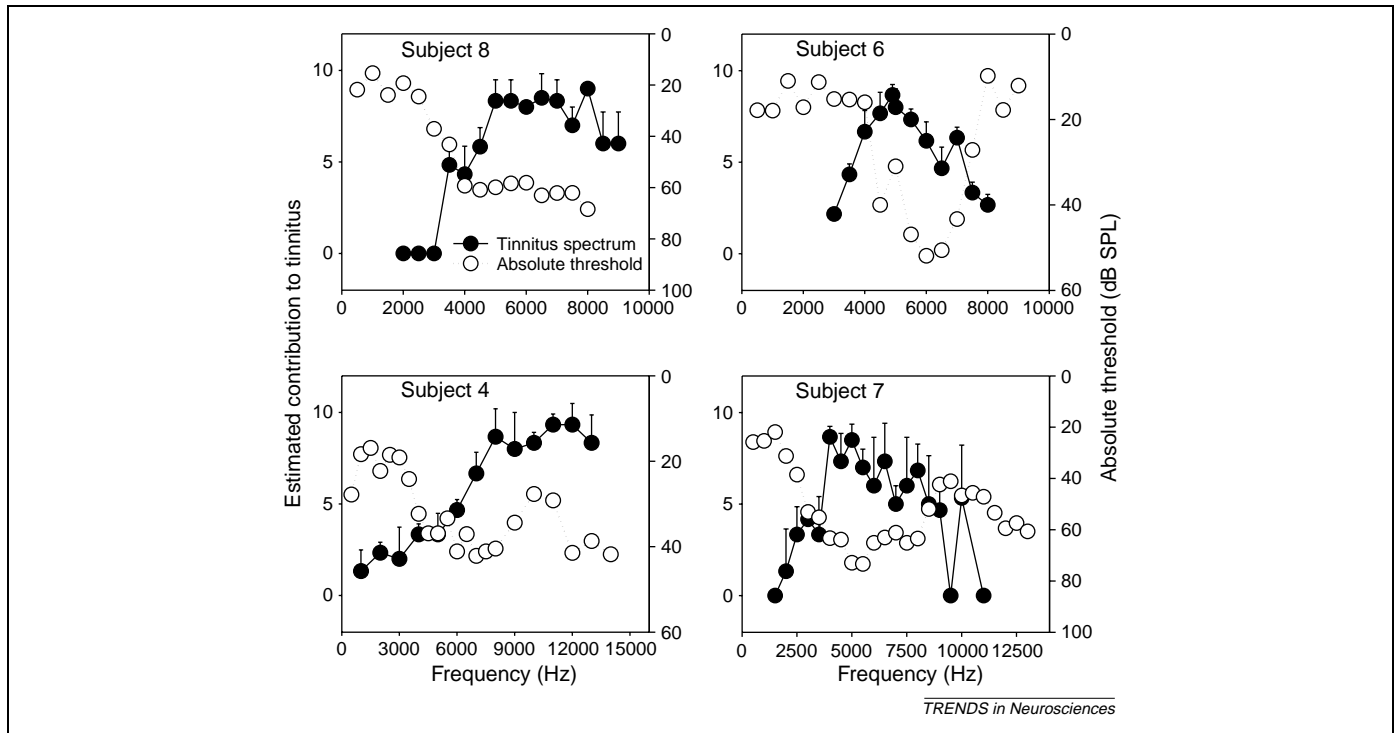

**Figure 3.** Estimated tinnitus spectrum in relation to hearing loss in four tinnitus subjects. The subjects are representative of ten subjects tested, all reporting tonal tinnitus. Etiology was auditory trauma (subjects 6 and 7), sudden hearing loss (subject 4, tinnitus for one year) or unknown (subject 8, tinnitus of three years). Hearing thresholds were measured in 500 Hz steps from 0.5 kHz to 8.0 kHz [up to 14 kHz when hearing loss at 8 kHz did not exceed 70 dB sound pressure level (SPL)] using a staircase method. After threshold determination, subjects adjusted the intensity of tones within the studied frequency range (one randomly selected tone at a time) to match the loudness of their tinnitus. Subjects then stated whether the frequency corresponded to one of the components of their tinnitus spectrum and, if it did, gave a rating on a 10-point scale (10 = tinnitus) of the extent to which the frequency was part of their tinnitus sensation. Frequencies were selected randomly from the tested range and repeated until a total of three measurements had been obtained for each frequency. Tones were presented monaurally either to the tinnitus ear (subjects 4, 6 and 7, unilateral cases) or to the ear where tinnitus was most pronounced (subject 8, a bilateral case). In each of the ten cases tested, the rated tinnitus spectrum spanned the region of hearing loss with no preponderance of edge-frequency ratings. Adapted from Ref. [54].

induced in auditory pathways by noise exposure and other tinnitus-inducing events occur in isolation. In particular, synchronous activity among neurons in the cortex reflects the number of shared axon collaterals (thalamocortical and corticocortical), the strength of their synapses, and their firing rates. Decreases in intracortical inhibition and increases in spontaneous activity occurring after loss of peripheral input to central neurons could promote development of synchronous activity by prolonging postsynaptic depolarization and increasing the likelihood of temporally coincident inputs converging on synapses [59]. Temporal integration might in turn enhance synaptic efficacies through Hebbian mechanisms [60], thus stabilizing synchronous network activity while temporally non-coincident inputs are segregated from the network. In the normal central auditory system, surround inhibition consequent on thalamocortical input would be expected to restrict synchronous activity to neurons tuned to properties of the acoustic stimulus, leading to normal auditory perception. However, when the constraints of intracortical inhibition are weakened, distributed synchronous activity could develop and stabilize over wider cortical territories, leading to the perception of sounds that are physically absent (tinnitus). Changes in synchronous activity observed in animal models of hearing loss could reflect network behavior in normal auditory perception that is set into relief by tinnitus.

### Alleviating tinnitus

At present, evidence for a contribution of neuroplastic processes to tinnitus is indirect, relying on documented properties of neural plasticity, including rapid remodeling of synaptic strengths by temporally coincident inputs, as revealed in physiological studies. Recent evoked potential studies of human subjects confirm that acoustic behavioral training modifies neural dynamics in the auditory cortex [61] with changes occurring in AII and AI [62], although more readily in AII, in agreement with animal data [63]. In the somatosensory system, segregation of sensory representations has been induced by behavioral training in animals [64]; in humans, it has been reported to prevent cortical map reorganization and phantom sensations in amputees [65] and to prevent map reorganization associated with focal hand dystonias in musicians [66]. Analogous procedures have not yet been applied to tinnitus, although findings from recent studies involving acoustic manipulations encourage their study. Adult cats show diminished hearing losses and near normal tonotopic maps following noise trauma if they are housed in the presence of high-frequency environmental sounds for several weeks following the trauma procedure (A.J. Noreña and J.J. Eggermont, unpublished). Exposure to high-frequency environmental sounds was more effective in reducing hearing loss and map reorganization than exposure to low-frequency sounds, although both

conferred benefit on map normalization compared with housing in a normal acoustic environment. These results, which are likely to depend on processes occurring in the cochlea [67] as well as in the brain, suggest a case for augmenting acoustic input through environmental and prosthetic interventions when hearing losses occur. When tinnitus subjects are trained explicitly at pitch discrimination using single pure tones in the region of hearing loss, the tinnitus percept can diminish for the trained frequencies while leaving the perception of nearby tinnitus frequencies intact [54].

At this time, tinnitus remains a significant challenge for the tinnitus sufferer and for the medical community. Drug treatment with GABA receptor agonists has been reported to give some relief [68], and psychological interventions that reduce anxiety and depression associated with tinnitus are reported by patients to be beneficial, even though the tinnitus sensation itself usually persists [69]. However, a decade or more of research is beginning to bear fruit. We are starting to understand how brain activity changes after hearing loss and how these changes can lead to tinnitus. Our experience has been that tinnitus sufferers want to know how their tinnitus is generated, and the present understanding, however incomplete, gives them reassurance and most importantly hope. And as we learn more about tinnitus, we learn more about its prevention and management, and about how the brain generates the sensation of sound.

#### Acknowledgements

We acknowledge the support of the Canadian Institutes of Health Research (CIHR) New Emerging Team grant on 'Understanding, treating and preventing tinnitus'.

#### References

- Heller, A.J. (2003) Classification and epidemiology of tinnitus. *Otolaryngol. Clin. North Am.* 36, 239–248
- Dobie, R.A. (2003) Depression and tinnitus. *Otolaryngol. Clin. North Am.* 36, 383–388
- Toh, S.T. *et al.* (2002) Prevalence of hearing disorders in Singapore military conscripts: a role for routine audiometry screening? *Singapore Med. J.* 43, 622–627
- Jastreboff, P.J. *et al.* (1988) Phantom auditory sensation in rats: an animal model for tinnitus. *Behav. Neurosci.* 102, 811–822
- Bauer, C.A. *et al.* (2000) Effects of chronic salicylate on GABAergic activity in rat inferior colliculus. *Hear. Res.* 147, 175–182
- Heffner, H.E. and Harrington, I.A. (2002) Tinnitus in hamsters following exposure to intense sound. *Hear. Res.* 170, 83–95
- Evans, E.F. *et al.* (1981) Animal models of tinnitus. In *Tinnitus, Ciba Foundation Symposium 85* (Evered, L. and Lawrenson, G. eds), pp. 108–138, Pitman
- Stypulkowski, P.H. (1990) Mechanisms of salicylate ototoxicity. *Hear. Res.* 46, 113–146
- Müller, M. *et al.* (2003) Auditory nerve fibre responses to salicylate revisited. *Hear. Res.* 183, 37–43
- Mulheran, M. (1999) The effects of quinine on cochlear nerve fibre activity in the guinea pig. *Hear. Res.* 134, 145–152
- Kiang, N.Y.-S. *et al.* (1970) Auditory-nerve activity in cats with normal and abnormal cochleas. In *Sensorineural Hearing Loss* (Wolstenholm, G.E.W. and Knight, J. eds), pp. 241–276, Churchill
- Lieberman, M.C. and Kiang, N.Y.-S. (1978) Acoustic trauma in cats. Cochlear pathology and auditory-nerve activity. *Acta Otolaryngol. Suppl.* 358, 1–63
- Guitton, M.J. *et al.* (2003) Salicylate induces tinnitus through activation of cochlear NMDA receptors. *J. Neurosci.* 23, 3944–3952
- Duan, M. *et al.* (2000) Complementary roles of neurotrophin 3 and N-methyl-D-aspartate antagonist in the protection of noise and aminoglycoside-induced ototoxicity. *Proc. Natl. Acad. Sci. U. S. A.* 97, 7597–7602
- House, J.W. and Brackman, D.E. (1981) Tinnitus: surgical treatment. In *CIBA Symposium 85: Tinnitus* (Evered, D. and Lawrenson, G. eds), pp. 204–212, Pitman
- Szczepaniak, W.S. and Møller, A.R. (1995) Effects of (–)-baclofen, clonazepam, and diazepam on tone exposure-induced hyperexcitability of the inferior colliculus in the rat: possible therapeutic implications for the pharmacological management of tinnitus and hyperacusis. *Hear. Res.* 97, 46–53
- Abbott, S.D. *et al.* (1999) Detection of glutamate decarboxylase isoforms in rat inferior colliculus following acoustic exposure. *Neuroscience* 93, 1375–1381
- Milbrandt, J.C. *et al.* (2000) GAD levels and muscimol binding in rat inferior colliculus following acoustic trauma. *Hear. Res.* 147, 251–260
- Salvi, R.J. *et al.* (1990) Enhanced evoked response amplitudes in the inferior colliculus of the chinchilla following acoustic trauma. *Hear. Res.* 50, 245–257
- Salvi, R.J. *et al.* (2000) Auditory plasticity and hyperactivity following cochlear damage. *Hear. Res.* 147, 261–274
- Jastreboff, P.J. and Sasaki, C.T. (1986) Salicylate-induced changes in spontaneous activity of single units in the inferior colliculus of the guinea pig. *J. Acoust. Soc. Am.* 80, 1384–1391
- Chen, G.D. and Jastreboff, P.J. (1995) Salicylate-induced abnormal activity in the inferior colliculus of rats. *Hear. Res.* 82, 158–178
- Eggermont, J.J. and Kenmochi, M. (1998) Salicylate and quinine selectively enhance spontaneous firing rates in secondary auditory cortex. *Hear. Res.* 117, 149–160
- Ochi, K. and Eggermont, J.J. (1996) Effects of salicylate on neural activity in cat primary auditory cortex. *Hear. Res.* 95, 63–76
- Eggermont, J.J. (1992) Salicylate-induced changes in the spontaneous activity in cat auditory cortex. In *Tinnitus 91* (Aran, J.-M. and Dauman, R. eds), pp. 293–298, Kugler Publications
- Kaltenbach, J.A. *et al.* (2002) Cisplatin-induced hyperactivity in the dorsal cochlear nucleus and its relation to outer hair cell loss: relevance to tinnitus. *J. Neurophysiol.* 88, 699–714
- Ochi, K. and Eggermont, J.J. (1997) Effects of quinine on neural activity in cat primary auditory cortex. *Hear. Res.* 105, 105–118
- Kaltenbach, J.A. *et al.* (1998) Changes in spontaneous neural activity in the dorsal cochlear nucleus following exposure to intense sound: relation to threshold shift. *Hear. Res.* 124, 78–84
- Eggermont, J.J. and Komiya, H. (2000) Moderate noise trauma in juvenile cats results in profound cortical topographic map changes in adulthood. *Hear. Res.* 142, 89–101
- Seki, S. and Eggermont, J.J. (2003) Changes in spontaneous firing rate and neural synchrony in cat primary auditory cortex after localized tone-induced hearing loss. *Hear. Res.* 180, 28–38
- Noreña, A.J. and Eggermont, J.J. (2003) Changes in spontaneous neural activity immediately after an acoustic trauma: implications for neural correlates of tinnitus. *Hear. Res.* 183, 137–153
- Brozowski, T.J. *et al.* (2002) Elevated fusiform cell activity in the dorsal cochlear nucleus of chinchillas with psychophysical evidence of tinnitus. *J. Neurosci.* 22, 2383–2390
- Chang, H. *et al.* (2002) Effects of acoustic trauma on dorsal cochlear nucleus neuron activity in slices. *Hear. Res.* 164, 59–68
- Kaltenbach, J.A. *et al.* (2000) Plasticity of spontaneous neural activity in the dorsal cochlear nucleus after intense sound exposure. *Hear. Res.* 147, 282–292
- Melcher, J.R. *et al.* (2000) Lateralized tinnitus studied with functional magnetic resonance imaging: abnormal inferior colliculus activation. *J. Neurophysiol.* 83, 1058–1072
- Giraud, A.L. *et al.* (1999) A selective imaging of tinnitus. *NeuroReport* 10, 1–5
- Lockwood, A.H. *et al.* (2001) The functional anatomy of gaze-evoked tinnitus and sustained lateral gaze. *Neurology* 56, 472–480
- Shore, S.E. *et al.* (2003) Effects of trigeminal ganglion stimulation on unit activity of ventral cochlear nucleus neurons. *Neuroscience* 119, 1085–1101
- Levine, R.A. *et al.* (2003) CNS somatosensory-auditory interactions elicit or modulate tinnitus. *Exp. Brain Res.* 153, 643–648
- Møller, A.R. *et al.* (1992) Some forms of tinnitus may involve the extralemnisal pathway. *Laryngoscope* 102, 1165–1171

- 41 Casace, A.T. (2003) Expanding the biological basis of tinnitus: crossmodal origins and the role of neuroplasticity. *Hear. Res.* 175, 112–132
- 42 Wallhäusser-Franke, E. *et al.* (1996) Salicylate alters 2-DG uptake in the auditory system: a model for tinnitus? *Neuroreport* 7, 1585–1588
- 43 Zhang, J.S. *et al.* (2003) Changes in [14C]-2-deoxyglucose uptake in the auditory pathway of hamsters previously exposed to intense sound. *Hear. Res.* 185, 13–21
- 44 Noreña, A.J. *et al.* (2003) Neural changes in cat auditory cortex after a transient pure-tone trauma. *J. Neurophysiol.* 90, 2387–2401
- 45 Muhlneckel, W. *et al.* (1998) Reorganization of auditory cortex in tinnitus. *Proc. Natl. Acad. Sci. U. S. A.* 95, 10340–10343
- 46 Rajan, R. (1998) Receptor organ damage causes loss of cortical surround inhibition without topographic plasticity changes. *Nat. Neurosci.* 1, 138–143
- 47 Flor, H. *et al.* (1995) Phantom-limb pain as a perceptual correlate of cortical reorganization following arm amputation. *Nature* 375, 482–484
- 48 Rauschecker, J.P. (1999) Auditory cortical plasticity: a comparison with other sensory systems. *Trends Neurosci.* 22, 74–80
- 49 Irvine, D.R. *et al.* (2000) Injury-induced reorganization in adult auditory cortex and its perceptual consequences. *Hear. Res.* 147, 188–199
- 50 Thai-Van, H. *et al.* (2003) Enhanced frequency discrimination near the hearing-loss cut-off: a consequence of central auditory plasticity induced by cochlear damage? *Brain* 126, 2235–2245
- 51 Dietrich, V. *et al.* (2001) Cortical reorganization in patients with high frequency cochlear hearing loss. *Hear. Res.* 158, 95–101
- 52 Henry, J.A. *et al.* (2001) Comparison of two computer-automated procedures for tinnitus pitch matching. *J. Rehabil. Res. Dev.* 38, 557–566
- 53 Tyler, R. (2000) Psychoacoustic measurement of tinnitus. In *Tinnitus Handbook* (Tyler, R. ed.), pp. 149–179, Singular Thomson Learning
- 54 Noreña, A. *et al.* (2002) Psychoacoustic characterization of the tinnitus spectrum: implications for the underlying mechanisms of tinnitus. *Audiol. Neurootol.* 7, 358–369
- 55 Vernon, J. and Meikle, M.B. (2003) Tinnitus: clinical measurement. *Otolaryngol. Clin. North Am.* 36, 293–305
- 56 Henry, J.A. and Meikle, M.B. (2000) Psychoacoustic measures of tinnitus. *J. Am. Acad. Audiol.* 11, 138–155
- 57 Caspary, D.M. *et al.* (1999) Age-related changes in GABA(A) receptor subunit composition and function in rat auditory system. *Neuroscience* 93, 307–312
- 58 Vernon, J. and Meikle, M.B. (2000) Tinnitus masking. In *Tinnitus Handbook* (Tyler, R. ed.), pp. 313–355, Singular Thomson Learning
- 59 Buonomano, D.V. and Merzenich, M.M. (1998) Net interaction between different forms of short-term synaptic plasticity and slow-IPSPs in the hippocampus and auditory cortex. *J. Neurophysiol.* 80, 1765–1774
- 60 Markram, H. *et al.* (1997) Regulation of synaptic efficacy by coincidence of postsynaptic APS and EPSPs. *Science* 275, 213–215
- 61 Tremblay, K. *et al.* (2001) Central auditory plasticity: changes in the N1–P2 complex after speech-sound training. *Ear Hear.* 22, 79–90
- 62 Bosnyak, D.J. *et al.* Distributed auditory cortical representations are modified when nonmusicians are trained at pitch discrimination with 40-Hz amplitude modulated tones. *Cereb. Cortex* (in press)
- 63 Diamond, D.M. and Weinberger, N.M. (1984) Physiological plasticity of single neurons in auditory cortex of the cat during acquisition of the pupillary conditioned response: II. Secondary field (AII). *Behav. Neurosci.* 98, 189–210
- 64 Wang, X. *et al.* (1995) Remodelling of hand representation in adult cortex determined by timing of tactile stimulation. *Nature* 378, 71–75
- 65 Flor, H. *et al.* (2001) Effect of sensory discrimination training on cortical reorganisation and phantom limb pain. *Lancet* 357, 1763–1764
- 66 Candia, V. *et al.* (2003) Effective behavioral treatment of focal hand dystonia in musicians alters somatosensory cortical organization. *Proc. Natl. Acad. Sci. U. S. A.* 100, 7942–7946
- 67 Schneider, M.E. *et al.* (2002) Rapid renewal of auditory hair bundles. *Nature* 418, 237–238
- 68 Johnson, R.M. *et al.* (1993) Use of alprazolam for relief of tinnitus: a double-blind study. *Arch. Otolaryngol. Head Neck Surg.* 119, 842–845
- 69 Jastreboff, P.J. and Jastreboff, M.M. (2003) Tinnitus retraining therapy for patients with tinnitus and decreased sound tolerance. *Otolaryngol. Clin. North Am.* 36, 321–336

### Important information for personal subscribers

Do you hold a personal subscription to a *Trends* journal? As you know, your personal print subscription includes free online access, previously accessed via BioMedNet. From now on, access to the full-text of your journal will be powered by **Science Direct** and will provide you with unparalleled reliability and functionality. Access will continue to be free; the change will not in any way affect the overall cost of your subscription or your entitlements.

The new online access site offers the convenience and flexibility of managing your journal subscription directly from one place. You will be able to access full-text articles, search, browse, set up an alert or renew your subscription all from one page.

In order to protect your privacy, we will not be automating the transfer of your personal data to the new site. Instead, we will be asking you to visit the site and register directly to claim your online access. This is one-time only and will only take you a few minutes.

#### Your new free online access offers you:

- Quick search • Basic and advanced search form • Search within search results • Save search • Articles in press • Export citations
- E-mail article to a friend • Flexible citation display • Multimedia components • Help files
- Issue alerts & search alerts for your journal

[http://www.trends.com/claim\\_online\\_access.htm](http://www.trends.com/claim_online_access.htm)